

**DESCRIPTION**

UCAN powder actuated fasteners are manufactured from high quality spring steel wire. For optimum hardness and toughness, all fasteners are heat treated to a core hardness of RC 50 - 54. To provide protection against corrosion, fasteners are zinc plated to a thickness of minimum 0.0003" (7.5µm).

**MECHANICAL PROPERTIES**

Tensile Strength = 1,800 MPa (269,700 psi)  
 Shear Strength = 1,160 MPa (168,200 psi)

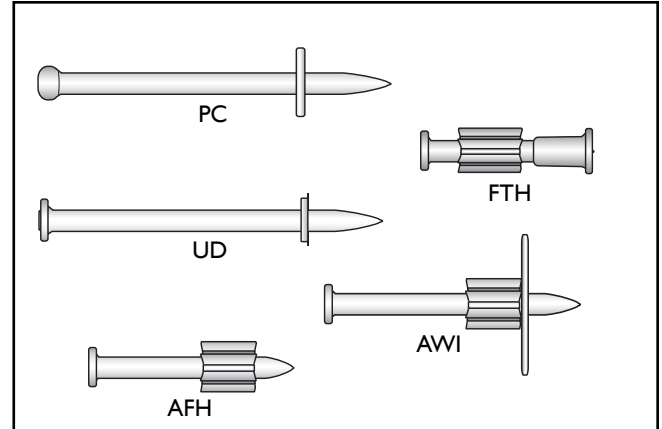

**APPLICATION LIMITS FOR FASTENING TO CONCRETE**

1. Do not fasten into cracks or spalled areas
2. Concrete thickness > 4" ( 100 mm )
3. Min. distance between fasteners > 3" (75 mm)
4. Min. edge distance > 3" ( 75 mm )
5. Shank Diameter = 0.145"
6. Other influencing factors are: concrete strength, age of concrete, aggregate size.
7. The optimal fastener penetration (e) for maximum holding power in concrete:
  - less than 2000 psi 1-1/2"
  - 2000 psi 1"
  - 5000 psi 3/4"

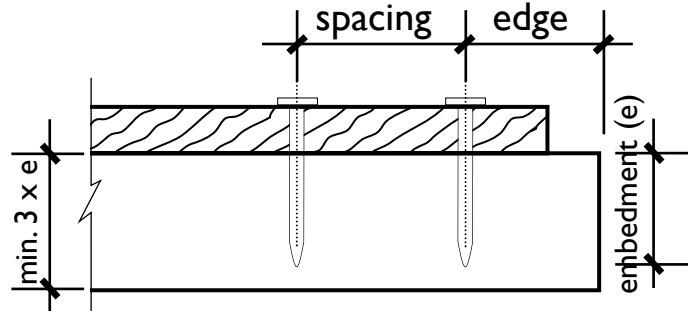

**ALLOWABLE WORKING LOADS IN CONCRETE (LBS)**

Shank Diameter	Penetration	Concrete Compressive Strength					
		2000 psi		3500 psi		5000 psi	
		Tension	Shear	Tension	Shear	Tension	Shear
0.145"	1"	110	150	180	180	215	200
	1-1/4"	128	180	190	200	222	234

All values shown includes the safety factor of 8:1

**APPLICATION LIMITS FOR FASTENING TO STEEL**

1. Do not fasten into steel thinner than the shank diameter
2. Min. steel thickness = 3/16"
3. Min. distance between fasteners > 2" (50 mm)
4. Min. edge distance > 1/2" (13 mm)
5. Fastener penetration = 3/16" to 1/2"
6. Shank Diameter = 0.145"
7. Other influencing factors are: steel
8. Min. distance from weld > 2" (50 mm)

Do not fasten into pre drilled holes unless the tool is equipped with an alignment device!

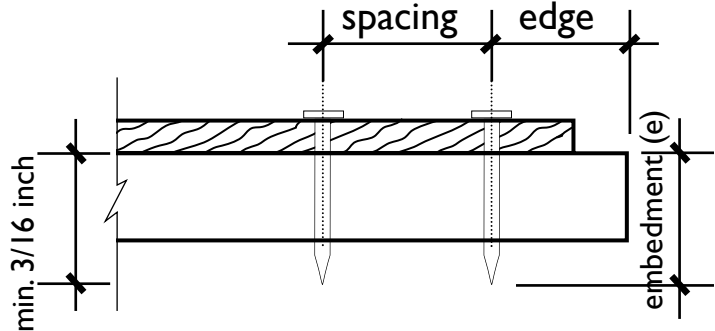

**ALLOWABLE WORKING LOADS IN STEEL (LBS)**

Shank Diameter	Steel thickness (inch)					
	1/4"		3/8"		1/2"	
	Tension	Shear	Tension	Shear	Tension	Shear
0.145"	453	645	511	705	690	705

All values shown includes the safety factor of 5:1

**SPECIFICATION**

The following sample specification clause is arranged for inclusion in any one of a variety of master specification sections utilizing the Construction Specifications Canada (CSC) format. Square brackets[] indicate alternatives, data required, or need for the specifier to fill in information.

**FASTENERS**

Fasteners shall be [type and length to suit load and fixture requirements] *Ucan Powder Actuated Fasteners*, supplied by Ucan Fastening Products. Fasteners shall be manufactured from AISI C1062 steel wire, heat treated to a minimum core hardness of 50RC, and zinc plated to a nominal thickness of 0.0003". Fastener installation shall follow Ucan's installation instructions.